

SERIE 400

COMFORT AND DESIGN

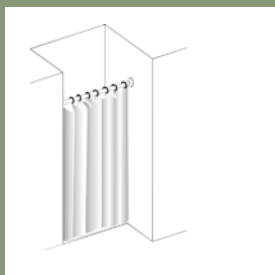

INDICE SERIE 400
INHALT SERIE 400
INDEX SERIE 400
INDICE SERIE 400

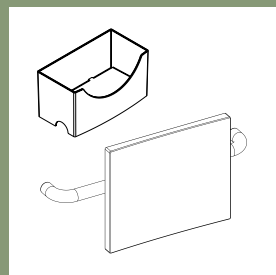
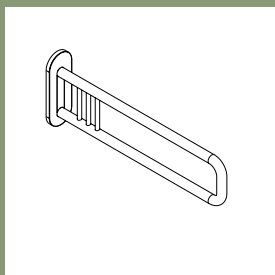
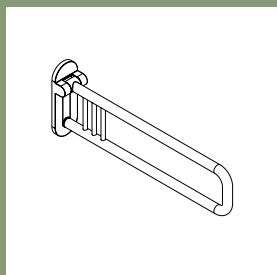
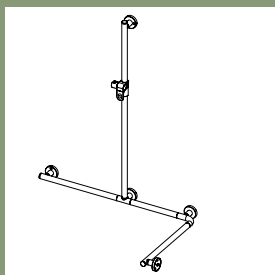
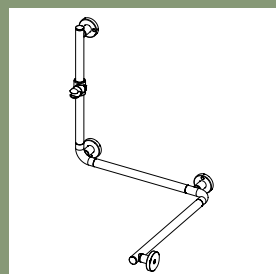
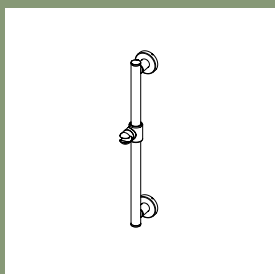
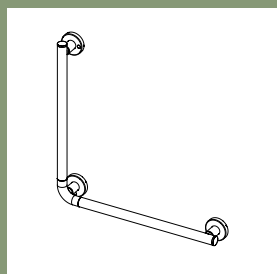
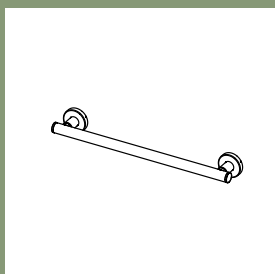
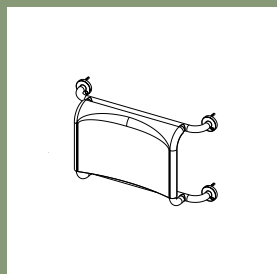
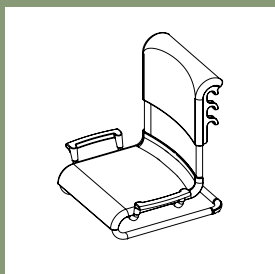



SERIE 400 - SISTEMA DI SEDILI E MANIGLIONI

Il sedile della serie 400 offre la combinazione perfetta tra sicurezza, comfort e design. I prodotti vengono sviluppati secondo le più attuali norme CE e TÜV. Progettato dal rinomato studio di design MM Design sono disponibili nei colori bianco/bianco, bianco/cromo lucido e nero/cromo lucido. Per sottolineare il design estetico e durativo dei prodotti tutti i componenti dei prodotti della serie 400 vengono realizzati in materiale anticorrosivo.

Un disegno aggiornato e moderno, massima funzionalità, materiali di alta qualità e un sistema modulare: queste sono le eccezionali caratteristiche del ampio sistema di maniglioni della serie 400. Il sistema di maniglioni della serie 400 STEEL consiste di acciaio Inox spazzolato ed è disponibile in cromo sia per l'applicazione nel settore sanitario privato che nel pubblico.

SERIE 400 - SITZ- UND GRIFFSYSTEM

Der Einhängesitz der Serie 400 stellt die perfekte Kombination von Sicherheit, Komfort und Design dar. Die Produkte wurden laut den aktuellsten CE und TÜV-Normen entwickelt, vom renomierten Designerstudio MM Design geformt und sind in den Farbversionen weiß/weiß, weiß/chrom und schwarz/chrom erhältlich. Um das zeitlose Design der Produkte zu unterstreichen, sind sämtliche Komponenten der Produkte der Serie 400 aus korrosionsbeständigen Materialien gefertigt.

Modernes zeitgemäßes Design, absolute Funktionalität, hochwertige Materialien und modulares Baukastensystem – das sind die herausragenden Merkmale des umfangreichen Griffsystems der Serie 400. Das Griffsystem Serie 400 STEEL besteht aus gebürstetem Edelstahl und ist in der Farbvariante chrom sowohl für die private, als auch öffentliche Anwendung im Sanitärbereich verfügbar.

SERIE 400 - SEAT AND GRAB BAR SYSTEM

The seat of the series 400 represents the perfect combination of security, comfort and design. The products were developed according to the most current European Union standards. All products are created by the renowned design studio MM Design and are white/white, white/chrome effect and black/chrome effect available in the colour versions. In order to underline the long-lived aesthetic Design of the products, all components of the products from the series 400 are manufactured from materials corrosion resistant.

A modern up-to-date design, absolute functionality, high-quality materials and modular construction system - those are the outstanding characteristics of the wide handle system of the series 400. The handle system of the series 400 STEEL consists of brushed stainless steel and is available in chrome for application in the private sanitary area as well as for public areas.

SERIE 400 - SISTEMA DE ASIENTOS Y ASIDEROS

El asiento de la serie 400 ofrece una combinación perfecta de seguridad, de comodidad y de diseño. Los productos fueron desarrollados según las normas más actuales de la unión europea, proyectado por el renombrado estudio de diseño MM Design disponibles en: blanco/blanco, blanco/cromo y negro/cromo. Para subrayar el diseño estético y duradero de los productos, todos los componentes de los productos de la serie 400 han sido realizados con materiales anticorrosivos.

Un diseño hasta la fecha moderno, materiales de alta calidad, funcionalidad absoluta y un sistema modular de la construcción - éstas son las características excepcionales del sistema de asideros de la serie 400. El sistema de asideros de la serie 400 STEEL consiste en el acero inoxidable cepillado y está disponible en cromo para el uso en el área sanitaria privada y para el público.

SERIE 400 EP



	RAL 9010	
Nero/Cromo Schwarz/Chrom Black/Chrome Negro/Cromo 05	Bianco Weiß White Blanco 31	Bianco/Cromo Weiß/Chrom White/Chrome Blanco/Cromo 69

Descrizione articolo Artikelbezeichnung Model description Descripción artículo	Modello Modell Model Modelo	Articolo Artikel Model Código	Misure Maße Sizes Medidas mm					
			A	B	C	D		
<p>Sedile agganciabile a maniglione* Einhängesitz für Griffsystem* Hanging seat for grab bar system* Asiento colgado por el sistema de asideros*</p>	A	0100 EP 31 PM	400	440	515	600		
	A	0100 EP 69 PM	400	440	515	600		
	A	0100 EP 05 PM	400	440	515	600		
<p>Sedile agganciabile a maniglione* Einhängesitz für Griffsystem* Hanging seat for grab bar system* Asiento colgado por el sistema de asideros*</p>	C	0300 EP 31 PM	400	440	515	600		
	C	0300 EP 69 PM	400	440	515	600		
	C	0300 EP 05 PM	400	440	515	600		
<p>Sedile agganciabile a maniglione con braccioli* Einhängesitz für Griffsystem mit Armlehnen* Hanging seat for grab bar system with armrests* Asiento colgado por el sistema de asideros con reposabrazos*</p>	A	0101 EP 31 PM	400	440	515	600		
	A	0101 EP 69 PM	400	440	515	600		
	A	0101 EP 05 PM	400	440	515	600		
<p>Sedile agganciabile a maniglione con braccioli* Einhängesitz für Griffsystem mit Armlehnen* Hanging seat for grab bar system with armrests* Asiento colgado por el sistema de asideros con reposabrazos*</p>	C	0301 EP 31 PM	400	440	515	600		
	C	0301 EP 69 PM	400	440	515	600		
	C	0301 EP 05 PM	400	440	515	600		
<p>Braccioli Armlehnen Armrests Reposabrazos</p>		0233 SA 31 PM						
		0233 SA 69 PM						
		0233 SA 05 PM						
<p>Schienale per WC Rückenlehne für WC Backrest for WC Respaldo para WC</p>		0500 EP 31 PM	300	540	180			

- * Prodotto viene fornito senza maniglione
- * Produkt wird ohne Haltegriff geliefert
- * Product will be delivered without grab bar
- * Producto sin sistema de asideros

MODEL A		MODEL C			
	Seduta semplice Einfache Sitzfläche Regular seat surface Asiento simple		Seduta con scorrimento d'acqua e ritaglio genitale Sitzfläche mit Wasserablauf und Genitaliausschnitt Seat surface with water drain and genital section Asiento con salida de agua y parte genitales		
				Min 40 mm Min ø 30 mm Max ø 34 mm Min 450 mm Min 550 mm	2 x 70 mm



SEDILE APPESO A BARRA

Il sedile appeso a barra è un prodotto ideale che unisce la sicurezza, il disegno e la comodità e rappresenta un mobiliario attraente, specialmente nella zona sanitaria pubblica. Questo sedile appeso a barra può essere usato con tutti i sistemi di maniglioni, che hanno un diametro massimo di 34 mm - inoltre la registrazione semplice verticale accerta un'applicazione versatile a 3 livelli. Le diversi varianti di modelli, colore e superfici di seduta completano il programma di questo prodotto di sicurezza.

EINHÄNGESITZ

Der Einhängesitz ist ein ideales Produkt, das Sicherheit, Design und Komfort vereint und stellt einen attraktiven Einrichtungsgegenstand, vor allem im öffentlichen Sanitärbereich dar. Dieser Einhängesitz kann bei allen gängigen Griffsystemen, die einen Durchmesser von maximal 34 mm aufweisen, eingesetzt werden – weiters gewährleistet die einfache Höhenverstellung auf 3 Ebenen eine vielseitige Anwendung. Die verschiedenen Modell-, Farb- und Sitzvarianten runden das Programm dieses Sicherheitsproduktes ab.

HANGING SEAT

The hanging seat is an ideal product that combines security, design and comfort and represents an attractive furnishing, particularly in the public sanitary area. This hanging seat can be used with all usual handle systems, which have a diameter of maximally 34 mm, - further the simple vertical adjustment ensures a versatile application to 3 levels. The different model, colour and seat variants complete this safety product.

ASIENTO COLGANTE

El asiento colgante es un producto ideal que une la seguridad, el diseño y la comodidad convirtiéndolo en un artículo atractivo, especialmente en la zona sanitaria pública. Este asiento suspendido en una barra puede ser utilizado con todos los sistemas de asideros, que ostenten en un diámetro de máximo 34 mm. Además el ajuste vertical simple asegura una aplicación versátil a 3 niveles. La diversidad de modelos, colores y asientos completan el programa de este producto de seguridad.



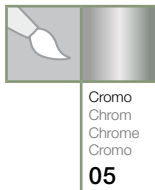
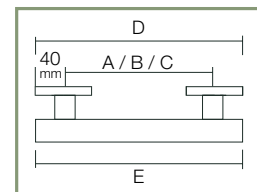

SERIE 400 STEEL SG

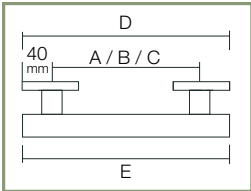

Descrizione articolo Artikelbezeichnung Model description Descripción artículo	Articolo Artikel Model Código	Misure Maße Sizes Medidas mm					
		A	B	C	D	E	
<p>Maniglione Wandhaltegriff Holding handle Asidero fijo</p>	4001 SG 05 PM	250			330	320	
	4002 SG 05 PM	450			530	520	
	4003 SG 05 PM	550			630	620	
	4004 SG 05 PM	650			730	720	
<p>Corrimano a parete Wandhandlauf Wall handrail Barra de seguridad de pared</p>	4005 SG 05 PM	1050			1130	1120	
	4006 SG 05 PM	1150			1230	1220	
	4007 SG 05 PM	1250			1330	1320	
<p>Maniglione 145° reversibile Wandhaltegriff 145° reversibel Wall handle 145° reversible Asidero fijo 145° reversible</p>	4010 SG 05 PM	580	480				
	4011 SG 05 PM	680	480				
	4012 SG 05 PM	680	580				
<p>Maniglione 90° reversibile Wandhaltegriff 90° reversibel Wall handle 90° reversible Asidero fijo 90° reversible</p>	4015 SG 05 PM	600	450				
	4016 SG 05 PM	700	450				
	4017 SG 05 PM	700	550				
	4018 SG 05 PM	800	650				
<p>Sostegno angolare con supporto verticale Wandhaltegriff mit Senkrechtstütze Holding handle with vertical support Asidero fijo de pared con soporte vertical</p>	4020 SG 05 PM	450	560	525			
	4021 SG 05 PM	450	560	775			
<p>Corrimano singolo per doccia Duschhandlauf einfach Single shower handrail Barra de seguridad simple</p>	4025 SG 05 PM	660	675				
	4026 SG 05 PM	760	775				
	4028 SG 05 PM	910	1075				
<p>Corrimano doppio per doccia Duschhandlauf doppelt Double shower handrail Barra de seguridad doble</p>	4030 SG 05 PM	660	1125				
	4031 SG 05 PM	760	1125				
	4032 SG 05 PM	910	1125				
<p>Mensola per maniglioni Ablage für Griffe Shelf for grab bars Estante para soporte</p>	0080 ZH 17 PM	107	205	110			
	0080 ZH 31 PM	107	205	110			

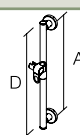
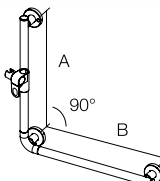
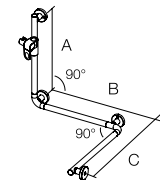
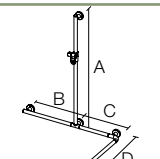
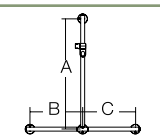

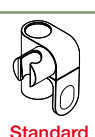
			RAL 9010
Cromo Chrom Chrome Cromo	Grigio Grau Grey Gris	Bianco Weiß White Blanco	
05	17	31	

Descrizione articolo Artikelbezeichnung Model description Descripción artículo	Articolo Artikel Model Código	Misure Maße Sizes Medidas mm					
		A	B	C	D	E	
 Sostegno per doccia con saliscendi Haltegriff vertikal mit Brausehalter Holding handle with shower holder Soporte para brazo de ducha	4050 SG 05 PM	800			880	870	
	4051 SG 05 PM	1000			1080	1070	
 Sostegno per doccia a 90° con saliscendi Haltegriff 90° mit Brausehalter Holding handle 90° with shower holder Soporte para brazo de ducha 90°	4055 SG 05 PM	800	600				
	4056 SG 05 PM	1000	600				
	4057 SG 05 PM	1000	700				
	4058 SG 05 PM	1200	450				
	4059 SG 05 PM	1200	700				
 Sostegno angolare con saliscendi Duschhandlauf mit Brausehalter Wall handrail with shower holder Asidero fijo de pared con soporte para brazo de ducha	4060 SG 05 PM	800	560	525			
	4061 SG 05 PM	1000	560	525			
	4062 SG 05 PM	1000	760	775			
	4064 SG 05 PM	1200	760	775			
 Sostegno angolo a T con saliscendi Duschhandlauf Ecke T-Form mit Brausehalter Handrail corner T-form with shower holder Barra de seguridad córner y T con brazo de ducha	4070 SG 05 PM	1150	425	535	725		
	4071 SG 05 PM	1150	525	585	875		
	4072 SG 05 PM	1150	525	635	875		
 Corrimano a T con saliscendi Handlauf T-Form mit Brausehalter Handrail T-form with shower holder Barra de seguridad T con brazo de ducha	4110 SG 05 PM	1150	425	525			
  Saliscendi sciolto Brausehalter lose Shower holder loose Soporte para ducha suelto Standard	4001 BR 05 PM	Abbinabile a tutti i maniglioni - colore cromo Passend für alle Griffe - Farbe chrom Suitable for all handles - colour chrome Adaptable para todo asideros - colore cromo					
  Saliscendi sciolto Brausehalter lose Shower holder loose Soporte para ducha suelto	3004 BR 17 PM	Abbinabile a tutti i maniglioni - colore grigio Passend für alle Griffe - Farbe grau Suitable for all handles - colour grey Adaptable para todo asideros - colore gris					

SERIE 400 VH + VN + VE + VU

TUBO CON TENDA DOCCIA
 DUSCHSTANGE MIT VORHANG
 TUBE WITH SHOWER CURTAIN
 BARRA CON CORTINA DE DUCHA

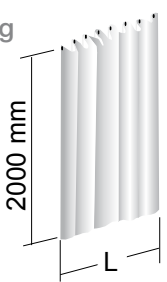
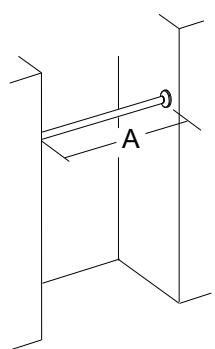
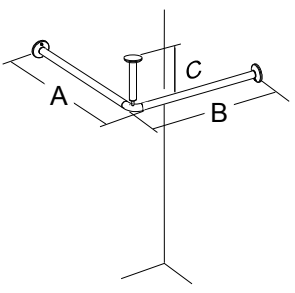
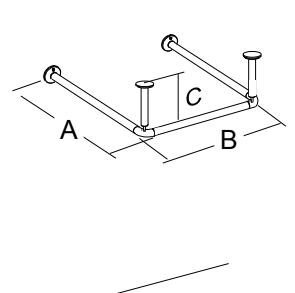
		Tende consigliate Passender Duschvorhang Suitable shower curtain Cortina aconsejable							
		Articolo Artikel Model Código		0007 VH 31 PM L = 1200 mm	0010 VH 31 PM L = 1500 mm	0013 VH 31 PM L = 1800 mm	0019 VH 31 PM L = 2400 mm	0025 VH 31 PM L = 3000 mm	0031 VH 31 PM L = 3600 mm
Nicchia - Nische - Niche - Huecos		4004 VN 05 PM A = 900 mm Anelli - Ringe - hooks - aillas 8	1x						
		4005 VN 05 PM A = 1000 mm Anelli - Ringe - hooks - aillas 10		1x					
		4007 VN 05 PM A = 1200 mm Anelli - Ringe - hooks - aillas 10		1x					
		4010 VN 05 PM A = 1500 mm Anelli - Ringe - hooks - aillas 12			1x				
Angolo - Ecke - Corner - Angular	 <p>C = 585 mm</p>	4004 VE 05 PM A = 900 mm B = 900 mm Anelli - Ringe - hooks - aillas 16				1x			
		4005 VE 05 PM A = 1000 mm B = 1000 mm Anelli - Ringe - hooks - aillas 16				1x			
		4007 VE 05 PM A = 1200 mm B = 1200 mm Anelli - Ringe - hooks - aillas 20					1x		
		4010 VE 05 PM A = 1500 mm B = 1500 mm Anelli - Ringe - hooks - aillas 24						1x	
A "U" / "U"-Form / "U"-form / En "U"	 <p>C = 585 mm</p>	4004 VU 05 PM A = 900 mm B = 900 mm Anelli - Ringe - hooks - aillas 8 + 16	1x			1x			
		4005 VU 05 PM A = 1000 mm B = 1000 mm Anelli - Ringe - hooks - aillas 10 + 16		1x		1x			
		4007 VU 05 PM A = 1200 mm B = 1200 mm Anelli - Ringe - hooks - aillas 10 + 20		1x			1x		
		4010 VU 05 PM A = 1500 mm B = 1500 mm Anelli - Ringe - hooks - aillas 12 + 24			1x			1x	

SERIE 400 VH + VN + VE + VU



	RAL 9010
Cromo Chrom Chrome Cromo	Bianco Weiß White Blanco
05	31

Descrizione articolo Artikelbezeichnung Model description Descripción artículo	Articolo Artikel Model Código	Misura piatto doccia Tassenmaß Tray size Medidas del plato mm	
		A	B
<p>Tenda nicchia Duschvorhang Nische Shower curtain niche Cortina ducha forma de cavidad</p>	0007 VH 31 PM	900	
	0010 VH 31 PM	1000	
	0010 VH 31 PM	1200	
	0013 VH 31 PM	1500	
<p>Tenda angolo Duschvorhang Ecke Shower curtain corner Cortina ducha angular</p>	0019 VH 31 PM	900	900
	0019 VH 31 PM	1000	1000
	0025 VH 31 PM	1200	1200
	0031 VH 31 PM	1500	1500
<p>Tenda a "U" Duschvorhang "U"-Form Shower curtain "U"-form Cortina ducha en forma "U"</p>	0007 VH 31 PM + 0019 VH 31 PM	900	900
	0010 VH 31 PM + 0019 VH 31 PM	1000	1000
	0010 VH 31 PM + 0025 VH 31 PM	1200	1200
	0013 VH 31 PM + 0031 VH 31 PM	1500	1500



<p>Tubo reggitenda nicchia Duschstange Nische Shower curtain tube niche Barra cortina ducha forma de cavidad</p>	4004 VN 05 PM	900	
	4005 VN 05 PM	1000	
	4007 VN 05 PM	1200	
	4010 VN 05 PM	1500	
<p>Tubo reggitenda angolo Duschstange Ecke Shower curtain tube corner Barra ducha angular</p>	4004 VE 05 PM	900	900
	4005 VE 05 PM	1000	1000
	4007 VE 05 PM	1200	1200
	4010 VE 05 PM	1500	1500
<p>Tubo reggitenda a "U" Duschstange "U"-Form Shower curtain tube "U"-form Barra ducha en forma "U"</p>	4004 VU 05 PM	900	900
	4005 VU 05 PM	1000	1000
	4007 VU 05 PM	1200	1200
	4010 VU 05 PM	1500	1500

SERIE 400 STEEL SG



Cromo	Bianco
Chrom	Weiß
Chrome	White
Cromo	Bianco
05	31



Descrizione articolo Artikelbezeichnung Model description Descripción artículo	Articolo Artikel Model Código	Misure Maße Sizes Medidas mm				
		A	B	C		
Appoggio ribaltabile Klappgriff Folding handle Asidero móvil	4045 SG 05 PM	650	280	100		
	4046 SG 05 PM	750	280	100		
	4047 SG 05 PM	850	280	100		
Appoggio ribaltabile con portarotolo reversibile Klappgriff mit Papierrollenhalter reversibel Folding handle with paper holder reversible Asidero móvil con portarrollos reversibile	4245 SG 05 PM	650	280	100		
	4246 SG 05 PM	750	280	100		
	4247 SG 05 PM	850	280	100		
Portarotolo di riserva Reserve Papierrollenhalter Additional paper holder Citapa de riserva	0262 BG 05 PM	115	150			
Tenda Duschvorhang Shower curtain Cortina ducha	0050 VH 31 PM	850	640-850			
Schienale per WC con maniglione Rückenlehne für WC mit Haltegriff Backrest for WC with handle Respaldo para WC con asidero	4090 ZH 05 PM	355	300	550	582	
Schienale per WC Rückenlehne für WC Backrest for WC Respaldo para WC	4095 ZH 05 PM	355	300	80		

Ø 32/33/34 mm

SERIE 400 STEEL SG



Cromo Chrom Chrome Cromo	Bianco Weiß White Blanco	
05	31	

Descrizione articolo Artikelbezeichnung Model description Descripción artículo	Articolo Artikel Model Código	Misure Maße Sizes Medidas mm				
		A	B	C		
<p>Maniglione di sostegno Stützgriff Support handle Asidero de apoyo</p>	4040 SG 05 PM	650	280	100		
	4041 SG 05 PM	750	280	100		
	4042 SG 05 PM	850	280	100		
<p>Maniglione di sostegno con portarotolo reversibile Stützgriff mit Papierrollenhalter reversibel Support handle with paper holder reversible Asidero de apoyo con portarollos reversibile</p>	4240 SG 05 PM	650	280	100		
	4241 SG 05 PM	750	280	100		
	4242 SG 05 PM	850	280	100		
<p>Portarotolo di riserva Reserve Papierrollenhalter Additional paper holder Citapa de reserva</p>	0262 BG 05 PM	115	150			
<p>Tenda Duschvorhang Shower curtain Cortina ducha</p>	0050 VH 31 PM	850	640-850			

Il maniglione di sostegno e ribaltabile sono in acciaio europeo spazzolato di alta qualità e sono disponibili con effetto cromato, soprattutto per uso nel bagno privato. Sono stati sviluppati in collaborazione con lo studio Talocci Design e sono la simbiosi perfetta tra design moderno e tecnica sicura. La portata di 130 kg, l'uso di fissaggi coperti e l'assenza di spigoli pericolosi, garantiscono un uso sicuro e delle buone caratteristiche di manutenzione. Sono disponibili con e senza porta rotolo.

Der Stütz- und Klappgriff besteht aus hochwertigem, gebürstetem europäischen Edelstahl und ist in der Farbvariante chrom-Effekt vorallem für das private Bad verfügbar. Entwickelt wurden sie in Zusammenarbeit mit dem Designstudio Talocci Design und ist die perfekte Symbiose aus modernem Design und sicherer Technik. Die Belastbarkeit von 130 kg, die Verwendung von abgedeckten Befestigungen und Vermeidung von Stoßkanten gewährleisten eine sichere Benutzung und gute Pflegeeigenschaften. Verfügbar sind sie mit oder ohne Papierrollenhalter.

The support and folding handle consists of high quality, European, brushed stainless steel and are available in chrome effect, mainly for application in the private sanitary area. The handles were developed in co-operation with the Design studio Talocci and is a perfect symbiosis between modern design and secure technology. The maximum load-bearing capacity of 130 kg, the use of covered fixings and curved edges ensure safe and easy use. They are available with or without paper holder.

El asidero de apoyo y móvil está fabricado en acero inoxidable de alta calidad, europeo, cepillado y está disponible en superficie cromada para el uso en el área sanitaria privada. Fue desarrollado en cooperación con el estudio Talocci Design y es una simbiosis perfecta entre el diseño moderno y tecnología segura. La capacidad de carga máxima de 130kg y el uso de fijaciones cubiertas y la ausencia de esquinas peligrosas, garantizan un uso seguro y un buen mantenimiento. Es disponible con o sin el portarollos.